

NOTES:

NO	PART NAME / NUMBER	DESCRIPTION	PCS
0	EXTRUDED FIN	78x100x25.5	1
1	SCREW	D6x17.5L	4
2	SPRING	W0.9x0D6.3x9.3Lx5.5N	4
3	E-CLIP	#3	4
4	THERMAL GREASE	X23-7762 30x30x0.15t	1
5	850-BP6060	68x68x5	1

		PROPRIETARY NOTE THIS DOCUMENT CONTAINS CONFIDENTIAL INFORMATION AND PROPRIETARY TO REGO ELECTRONICS AND SHALL NOT BE REPRODUCED OR DISCLOSED TO OTHER DOCUMENTS OR USED FOR ANY PURPOSE OTHER THAN THAT FOR WHICH WAS OBTAINED WITHOUT THE EXPRESSED WRITTEN CONSENT OF REGO ELECTRONICS.			
		PROJECT	APPROVED	MATERIAL	DATE
TITLE		CHECKED	FINISH	SCALE	.X ± 0.30
HEAT SINK ASSEMBLY		LEVI	SEE NOTE	1:1	.XX ± 0.20
PART NO	DRAWN	VIC	UNITS	REV	.XXX ± 0.10
RG5110			mm	A	SHEET 1 OF 1

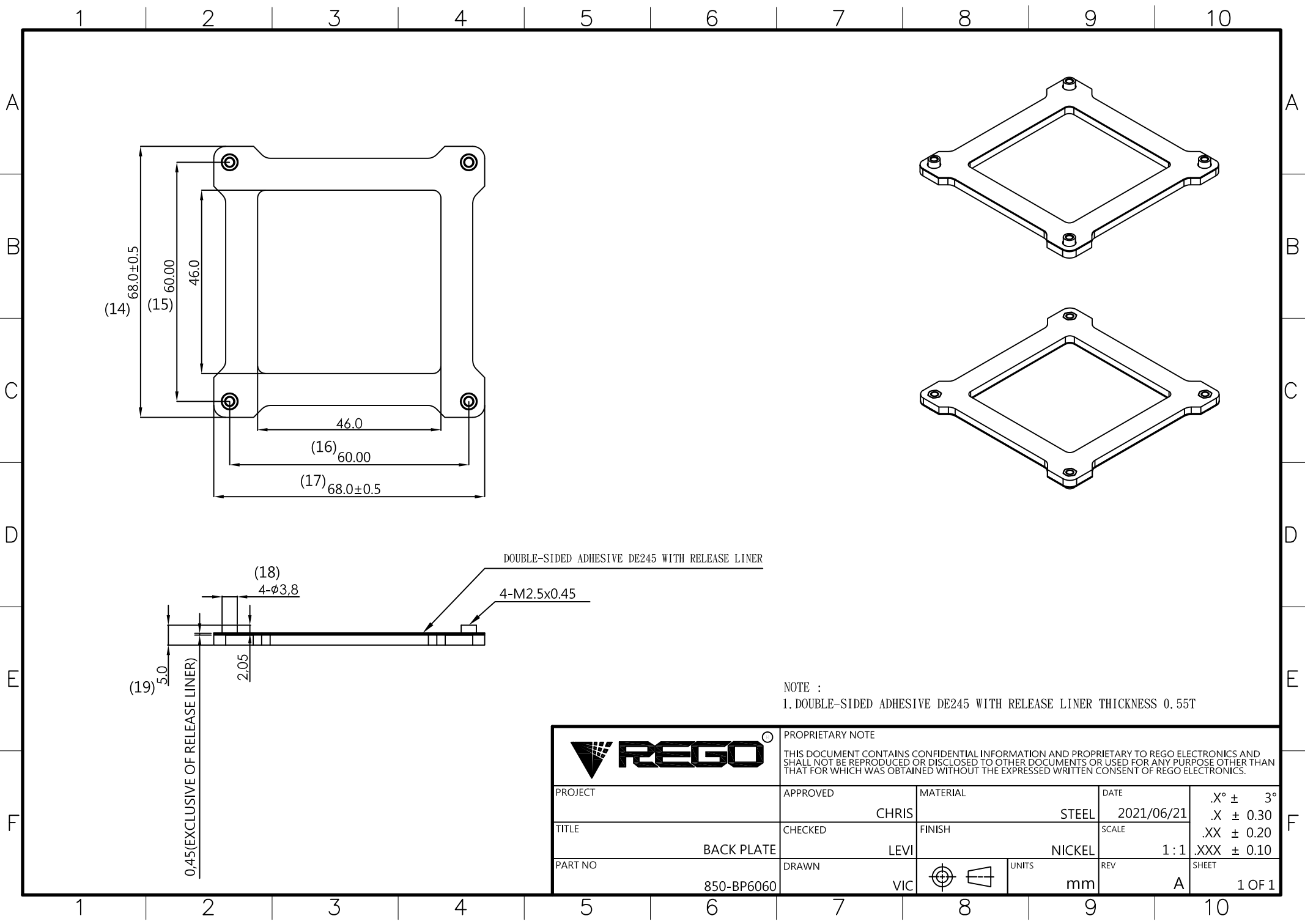



DOUBLE-SIDED ADHESIVE DE245 WITH RELEASE LINER

4-M2.5x0.45

(18)
4- ϕ 3.8

(19) 5.0
0.45 (EXCLUSIVE OF RELEASE LINER)

NOTE :
1. DOUBLE-SIDED ADHESIVE DE245 WITH RELEASE LINER THICKNESS 0.55T

		PROPRIETARY NOTE THIS DOCUMENT CONTAINS CONFIDENTIAL INFORMATION AND PROPRIETARY TO REGO ELECTRONICS AND SHALL NOT BE REPRODUCED OR DISCLOSED TO OTHER DOCUMENTS OR USED FOR ANY PURPOSE OTHER THAN THAT FOR WHICH WAS OBTAINED WITHOUT THE EXPRESSED WRITTEN CONSENT OF REGO ELECTRONICS.			
		PROJECT	APPROVED	MATERIAL	DATE
TITLE	CHECKED	FINISH	SCALE	.XX ± 0.20	F
PART NO	DRAWN	UNITS	REV	.XXX ± 0.10	
		 	mm	A	1 OF 1

PROJECT	APPROVED	MATERIAL	DATE	.X° ± 3°
	CHRIS	STEEL	2021/06/21	.X ± 0.30
TITLE	CHECKED	FINISH	SCALE	.XX ± 0.20
BACK PLATE	LEVI	NICKEL	1 : 1	.XXX ± 0.10
PART NO	DRAWN	UNITS	REV	SHEET
850-BP6060	VIC	mm	A	1 OF 1