

Hybrid Forge Heat Sinks



1.Material : Aluminum 6063

2.Finish : Black anodize

SPECIFICATION

| L X W (mm) | H (mm) | Fin |
|------------|---------|------|
| 19x19 | 6,10,13 | LINE |
| 21x21 | 6,10,13 | LINE |
| 22x22 | 6,10,13 | LINE |
| 23x23 | 6,10,13 | LINE |
| 24x24 | 6,10,13 | LINE |
| 25x25 | 6,10,13 | LINE |
| 27x27 | 6,10,13 | LINE |
| 29x29 | 6,10,13 | LINE |
| 31x31 | 6,10,13 | LINE |
| 33x33 | 6,10,13 | LINE |
| 34x34 | 6,10,13 | LINE |
| 35x35 | 6,10,13 | LINE |
| 37.5x37.5 | 6,10,13 | LINE |
| 40x40 | 6,10,13 | LINE |
| 42.5x42.5 | 6,10,13 | LINE |
| 45x45 | 6,10,13 | LINE |
| 50x50 | 6,10,13 | LINE |

Hybrid Forge Heat Sinks

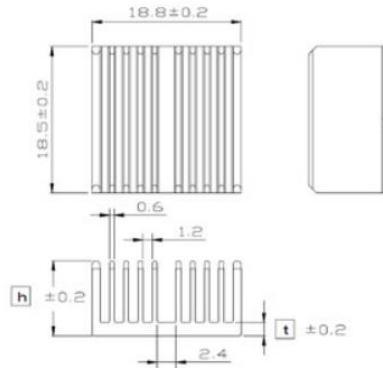

Material : Aluminum 6063

Finish : Black anodize

| Model No. | Height (mm) | Thickness (mm) |
|-----------|-------------|----------------|
| H 19-06 | 6.3 | 1.7 |
| H 19-10 | 9.5 | 1.7 |
| H 19-13 | 12.7 | 1.7 |

SPECIFICATION

:: Rth (°C/W) ::

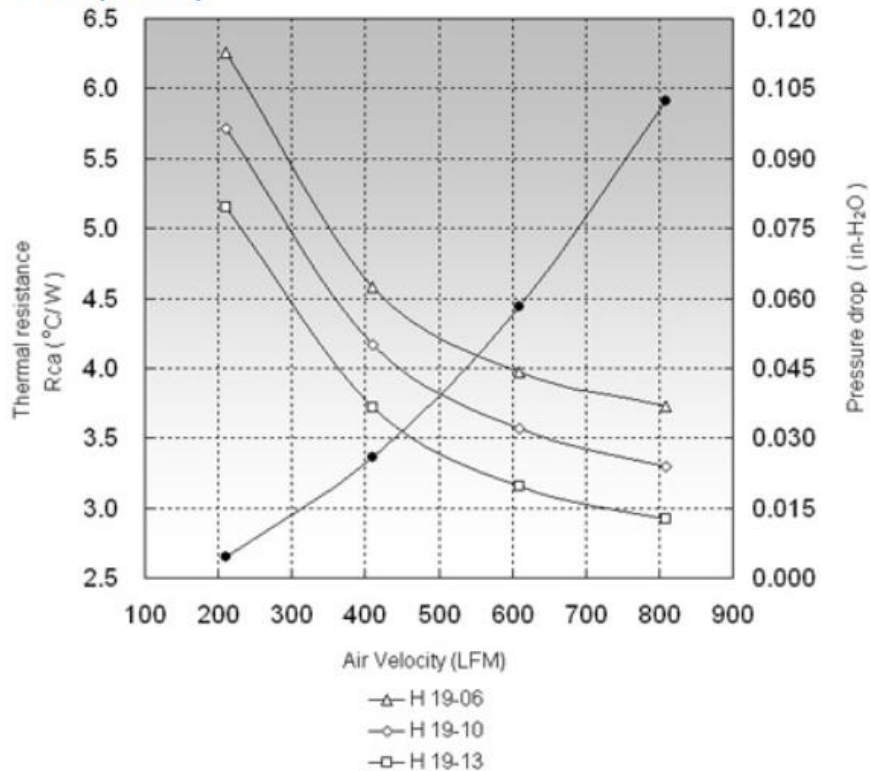

Hybrid Forge Heat Sinks

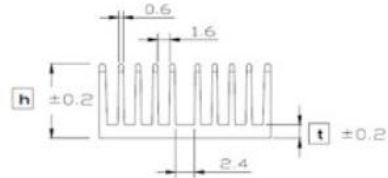
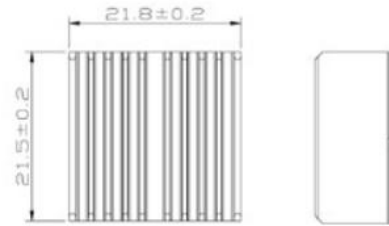

Material : Aluminum 6063

Finish : Black anodize

| Model No. | Height (mm) | Thickness (mm) |
|-----------|-------------|----------------|
| H 21-06 | 6.3 | 1.7 |
| H 21-10 | 9.5 | 1.7 |
| H 21-13 | 12.7 | 1.7 |

SPECIFICATION

:: Rth (°C/W) ::

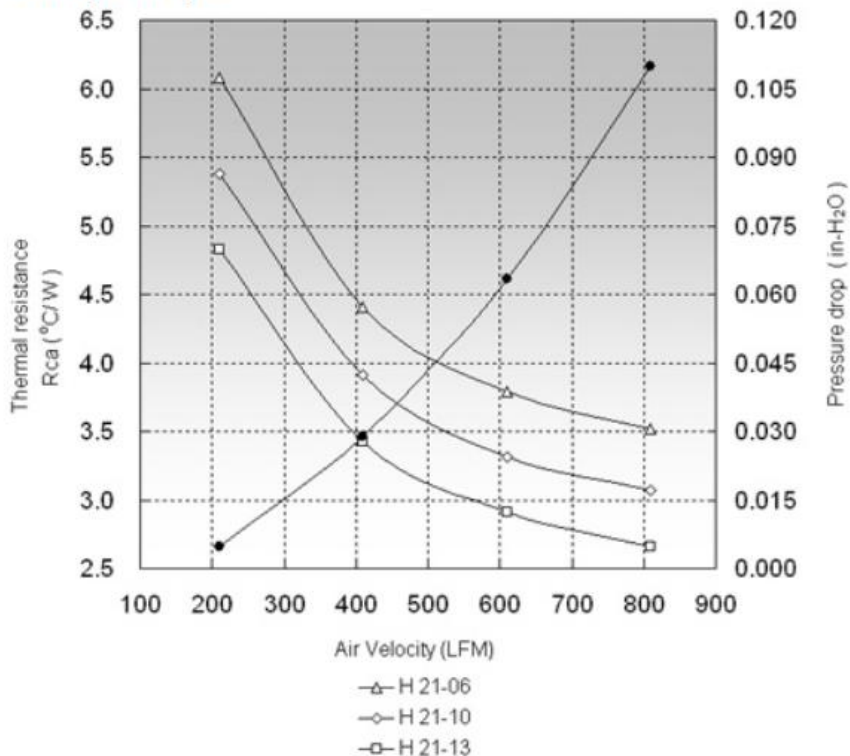

Hybrid Forge Heat Sinks

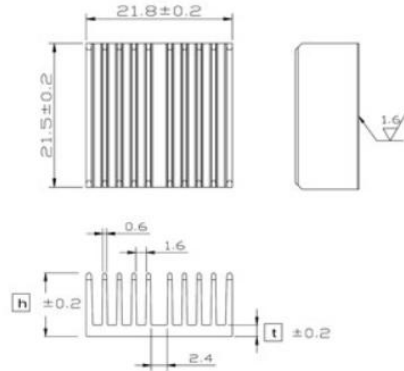

Material : Aluminum 6063

Finish : Black anodize

| Model No. | Height (mm) | Thickness (mm) |
|-----------|-------------|----------------|
| H 22-06 | 6.3 | 1.7 |
| H 22-10 | 9.5 | 1.7 |
| H 22-13 | 12.7 | 1.7 |

SPECIFICATION

:: Rth (°C/W) ::

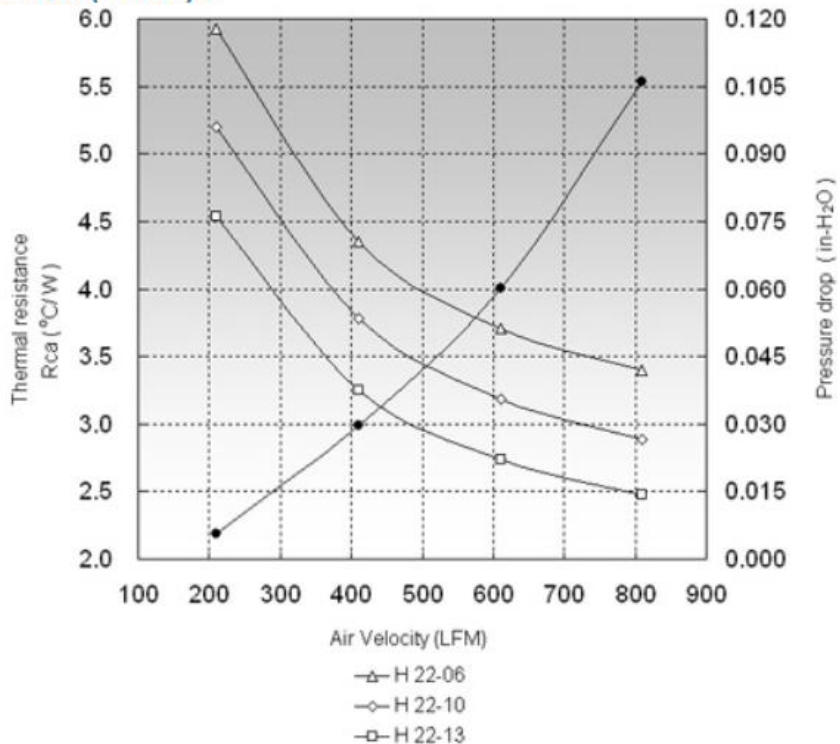

Hybrid Forge Heat Sinks

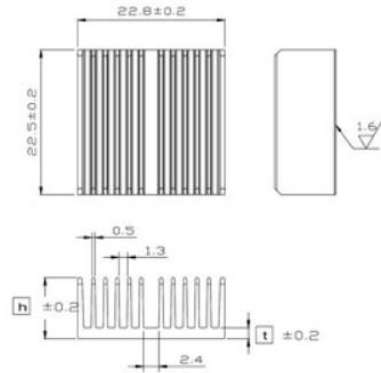

Material : Aluminum 6063

Finish : Black anodize

| Model No. | Height (mm) | Thickness (mm) |
|-----------|-------------|----------------|
| H 23-06 | 6.3 | 1.7 |
| H 23-10 | 9.5 | 1.7 |
| H 23-13 | 12.7 | 1.7 |

SPECIFICATION

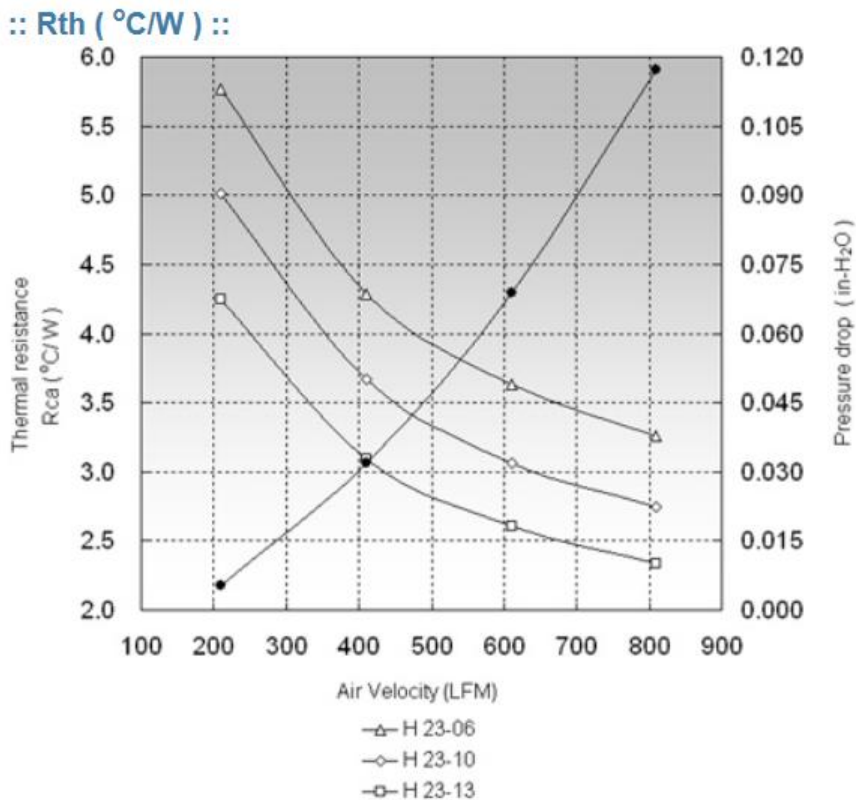

Hybrid Forge Heat Sinks

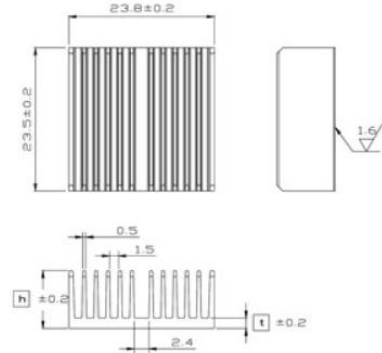

Material : Aluminum 6063

Finish : Black anodize

| Model No. | Height (mm) | Thickness (mm) |
|-----------|-------------|----------------|
| H 24-06 | 6.3 | 1.7 |
| H 24-10 | 9.5 | 1.7 |
| H 24-13 | 12.7 | 1.7 |

SPECIFICATION

:: Rth (°C/W) ::

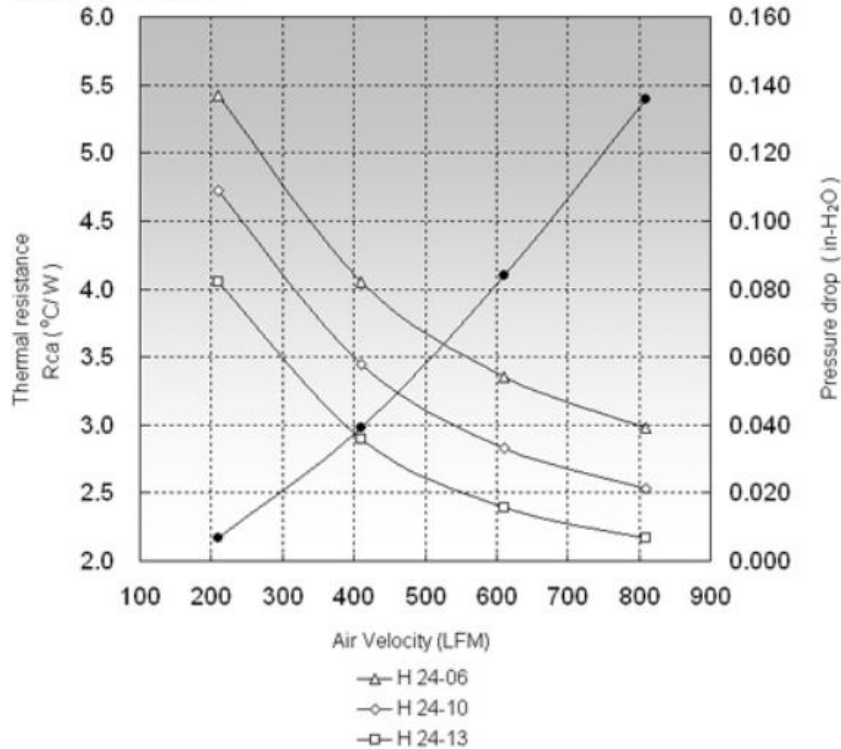

Hybrid Forge Heat Sinks

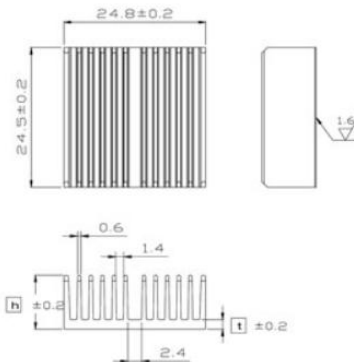

Material : Aluminum 6063

Finish : Black anodize

| Model No. | Height (mm) | Thickness (mm) |
|-----------|-------------|----------------|
| H 25-06 | 6.3 | 1.7 |
| H 25-10 | 9.5 | 1.7 |
| H 25-13 | 12.7 | 1.7 |

SPECIFICATION

:: Rth (°C/W) ::

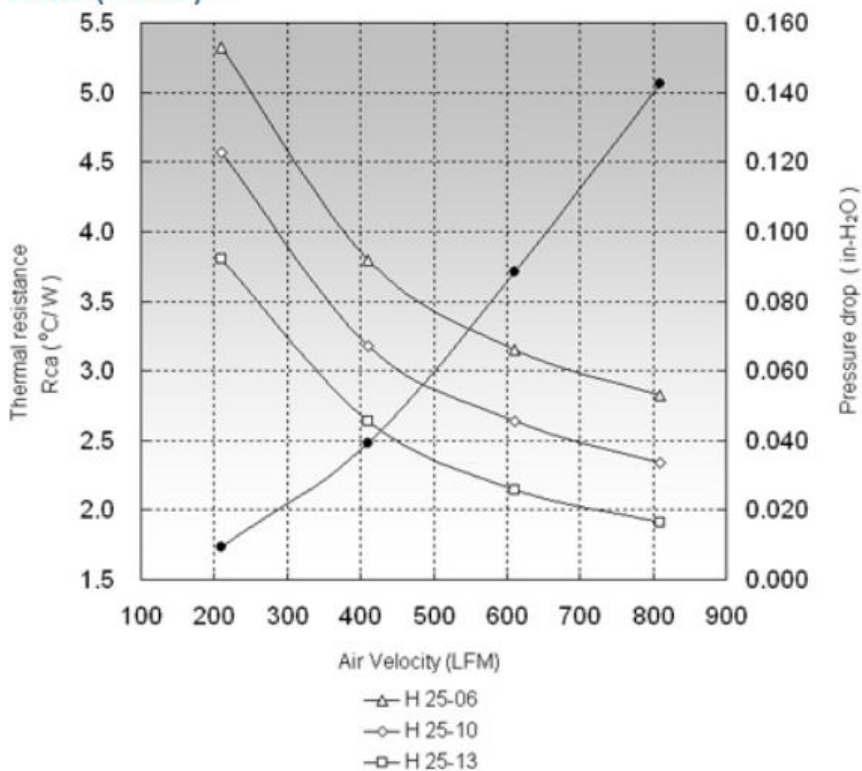

Hybrid Forge Heat Sinks

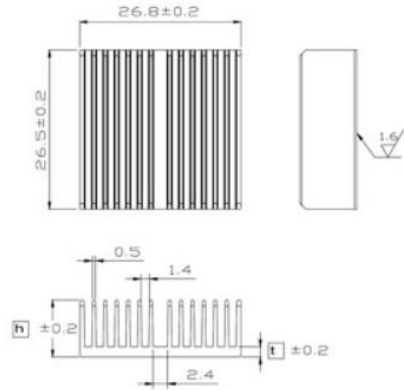

Material : Aluminum 6063

Finish : Black anodize

| Model No. | Height (mm) | Thickness (mm) |
|-----------|-------------|----------------|
| H 27-06 | 6.3 | 1.7 |
| H 27-10 | 9.5 | 1.7 |
| H 27-13 | 12.7 | 1.7 |

SPECIFICATION

:: Rth (°C/W) ::

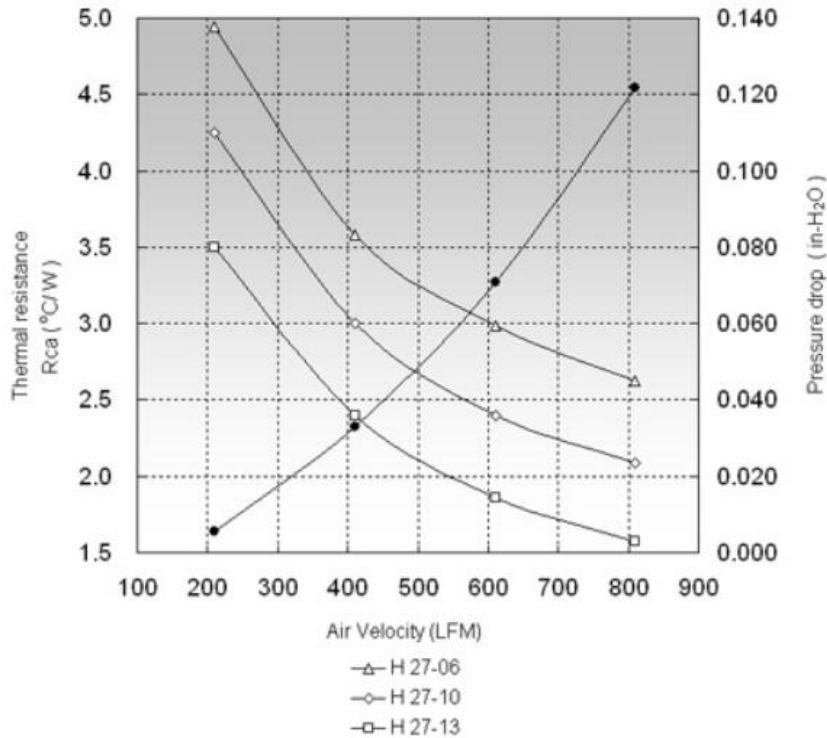

Hybrid Forge Heat Sinks

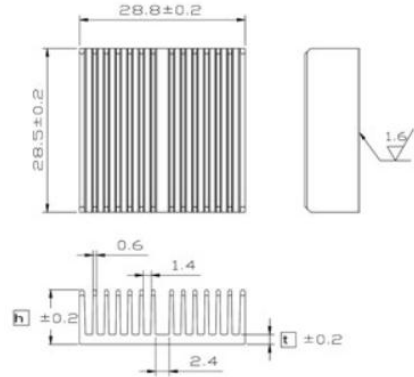

Material : Aluminum 6063

Finish : Black anodize

| Model No. | Height (mm) | Thickness (mm) |
|-----------|-------------|----------------|
| H 29-06 | 6.3 | 1.7 |
| H 29-10 | 9.5 | 1.7 |
| H 29-13 | 12.7 | 1.7 |

SPECIFICATION

:: Rth (°C/W) ::

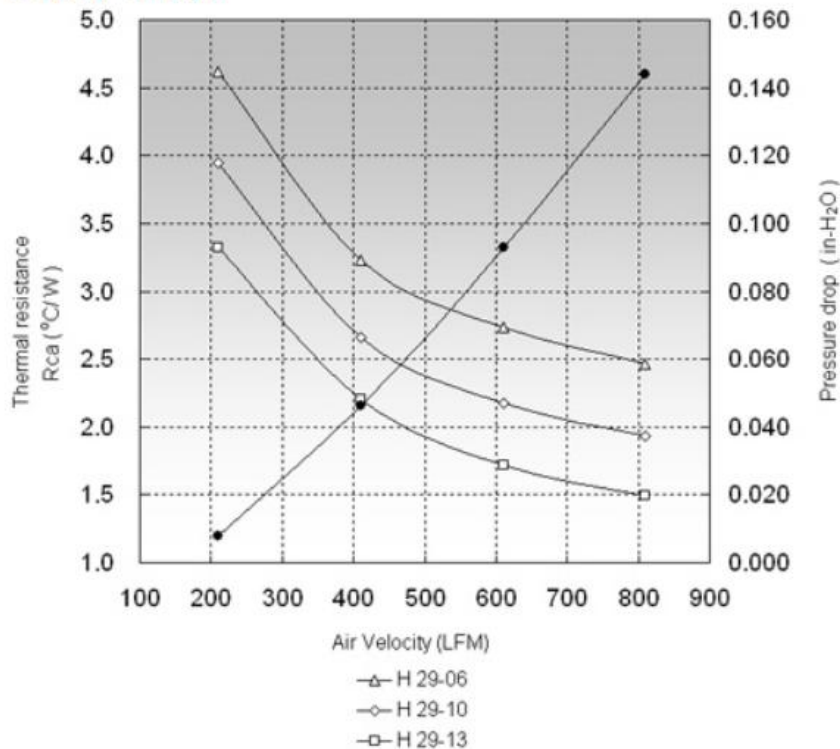

Hybrid Forge Heat Sinks

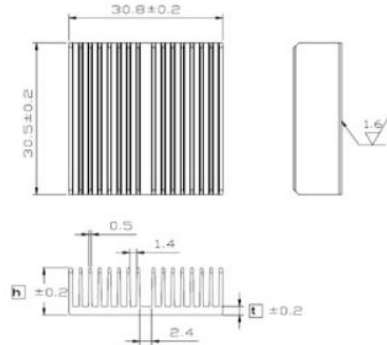

Material : Aluminum 6063

Finish : Black anodize

| Model No. | Height (mm) | Thickness (mm) |
|-----------|-------------|----------------|
| H 31-06 | 6.3 | 1.7 |
| H 31-10 | 9.5 | 1.7 |
| H 31-12 | 12.0 | 1.7 |
| H 31-13 | 12.7 | 1.7 |

SPECIFICATION

:: Rth (°C/W) ::

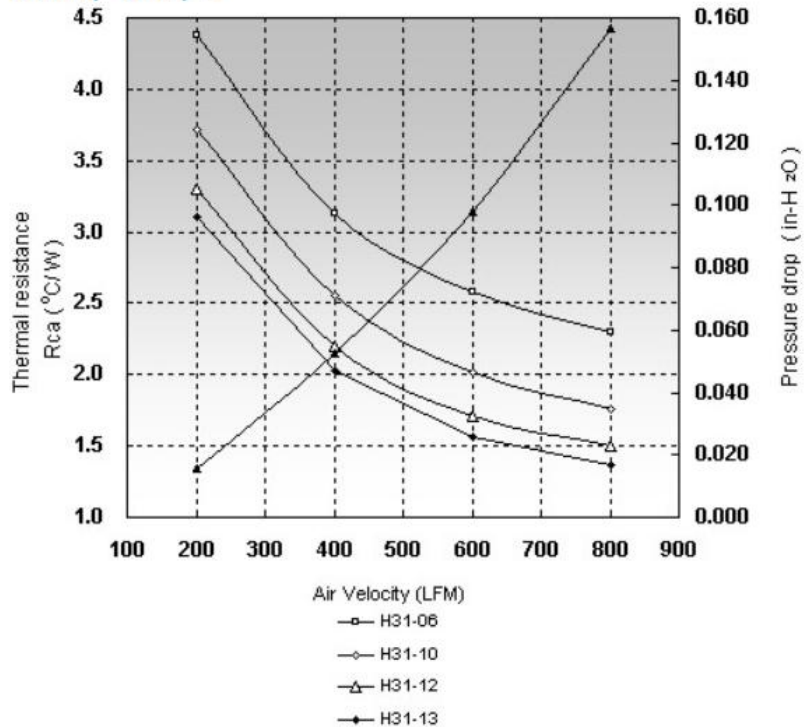

Hybrid Forge Heat Sinks

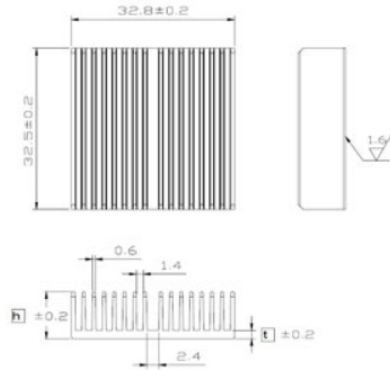

Material : Aluminum 6063

Finish : Black anodize

| Model No. | Height (mm) | Thickness (mm) |
|-----------|-------------|----------------|
| H 33-06 | 6.3 | 1.7 |
| H 33-10 | 9.5 | 1.7 |
| H 33-13 | 12.7 | 1.7 |

SPECIFICATION

:: Rth (°C/W) ::

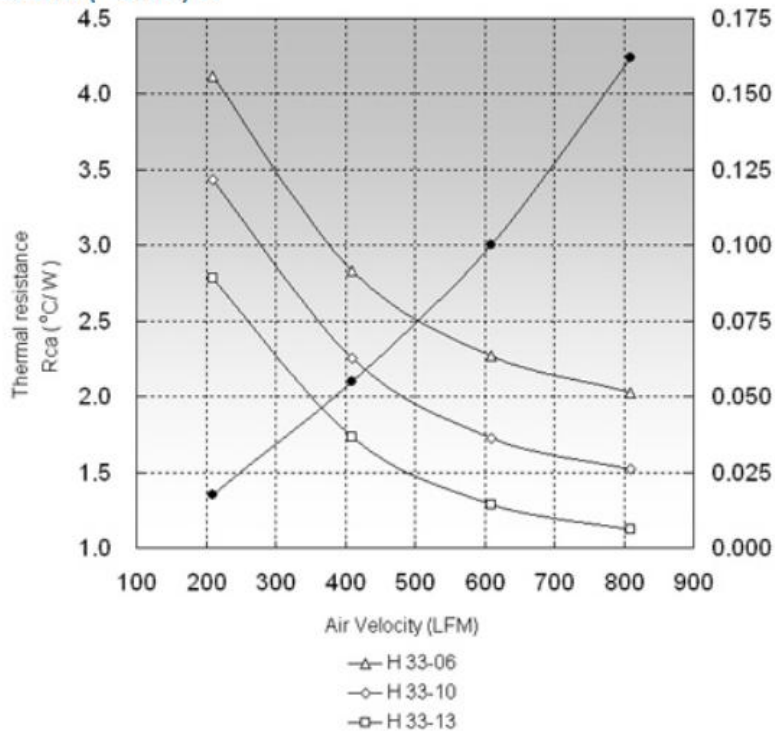

Hybrid Forge Heat Sinks

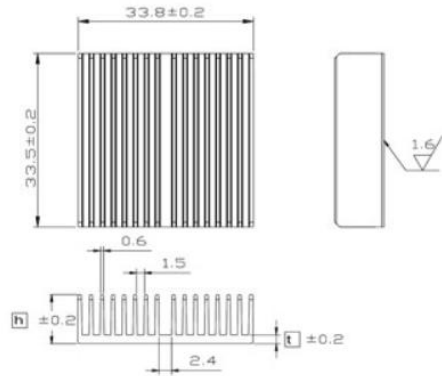

Material : Aluminum 6063

Finish : Black anodize

| Model No. | Height (mm) | Thickness (mm) |
|-----------|-------------|----------------|
| H 34-06 | 6.3 | 1.7 |
| H 34-10 | 9.5 | 1.7 |
| H 34-13 | 12.7 | 1.7 |

SPECIFICATION

:: R_{th} (°C/W) ::

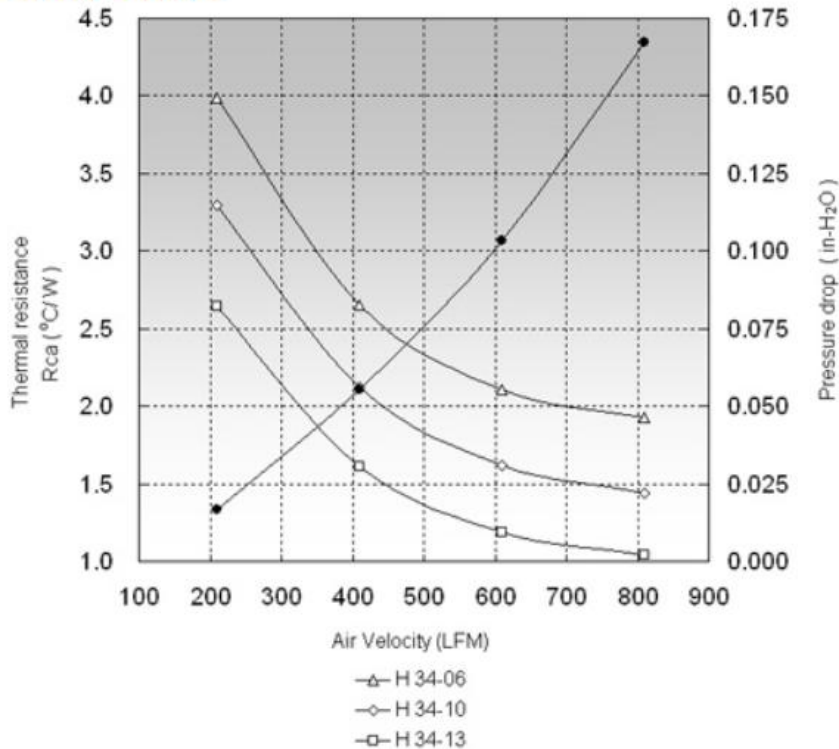

Hybrid Forge Heat Sinks

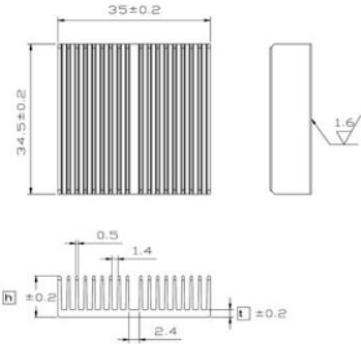
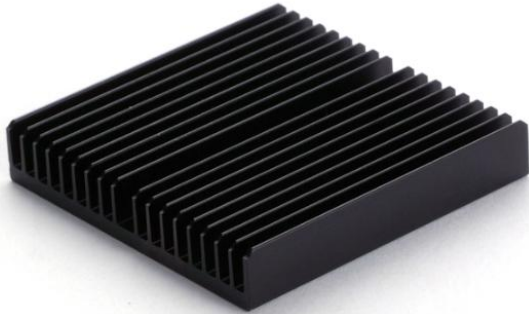

Material : Aluminum 6063

Finish : Black anodize

| Model No. | Height (mm) | Thickness (mm) |
|-----------|-------------|----------------|
| H 35-06 | 6.3 | 1.7 |
| H 35-10 | 9.5 | 1.7 |
| H 35-13 | 12.7 | 1.7 |

SPECIFICATION

:: Rth (°C/W) ::

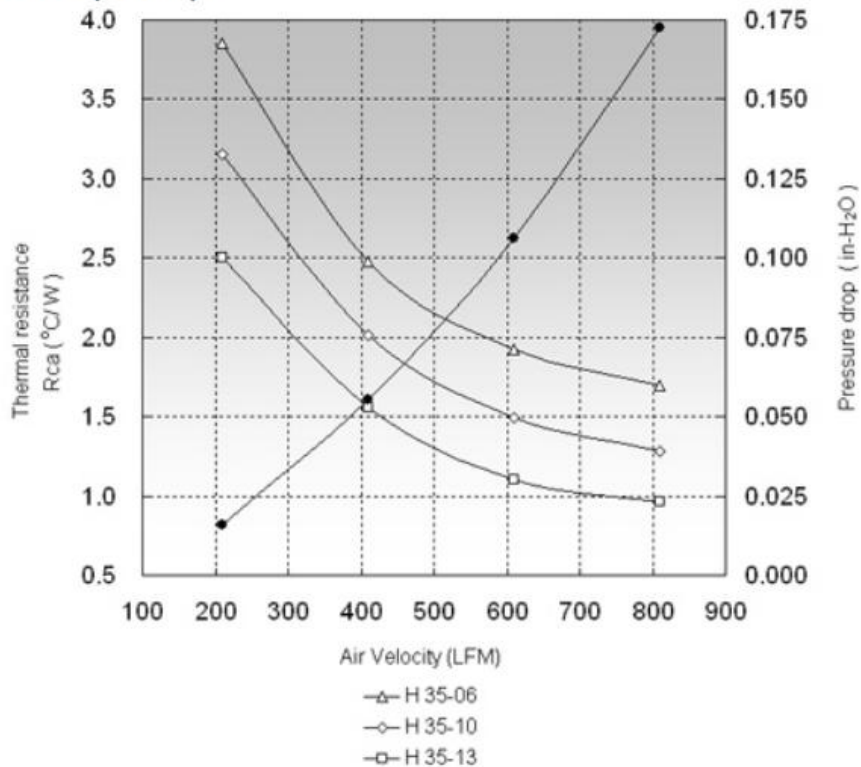

Hybrid Forge Heat Sinks

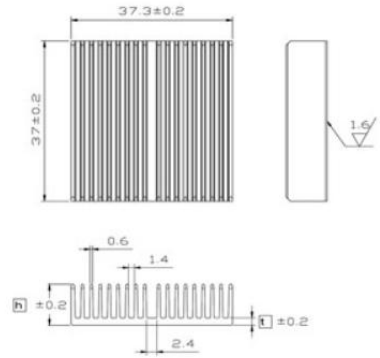

Material : Aluminum 6063

Finish : Black anodize

| Model No. | Height (mm) | Thickness (mm) |
|-----------|-------------|----------------|
| H 37.5-06 | 6.3 | 1.7 |
| H 37.5-10 | 9.5 | 1.7 |
| H 37.5-13 | 12.7 | 1.7 |

SPECIFICATION

:: Rth (°C/W) ::

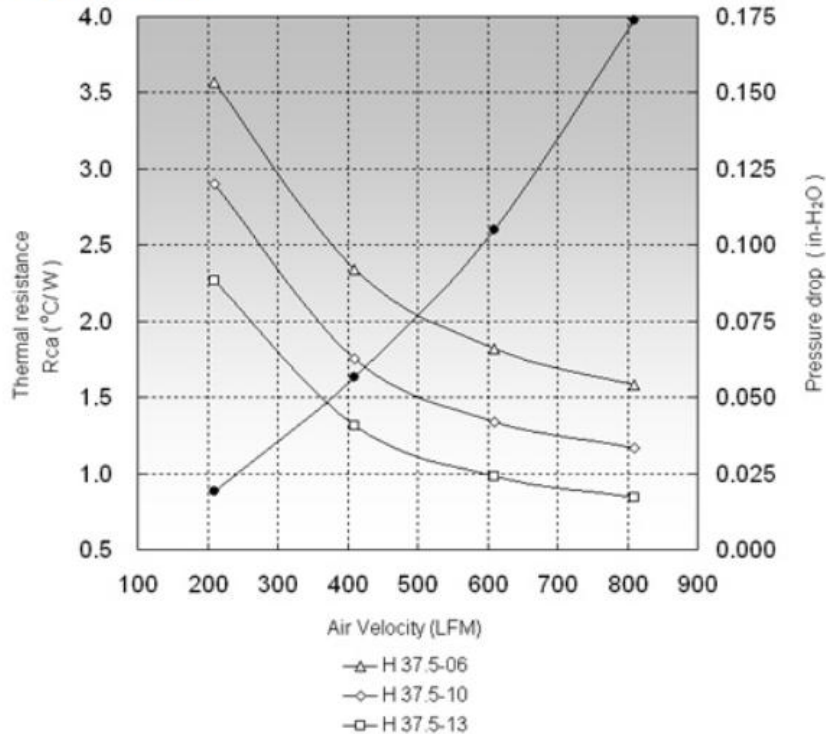

Hybrid Forge Heat Sinks

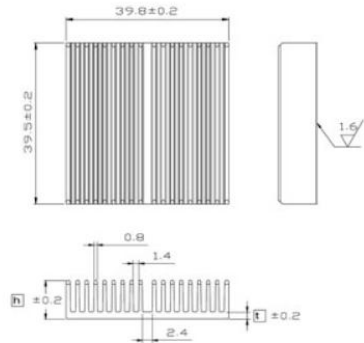

Material : Aluminum 6063

Finish : Black anodize

| Model No. | Height (mm) | Thickness (mm) |
|-----------|-------------|----------------|
| H 40-06 | 6.3 | 1.7 |
| H 40-10 | 9.5 | 1.7 |
| H 40-13 | 12.7 | 1.7 |

SPECIFICATION

:: Rth (°C/W) ::

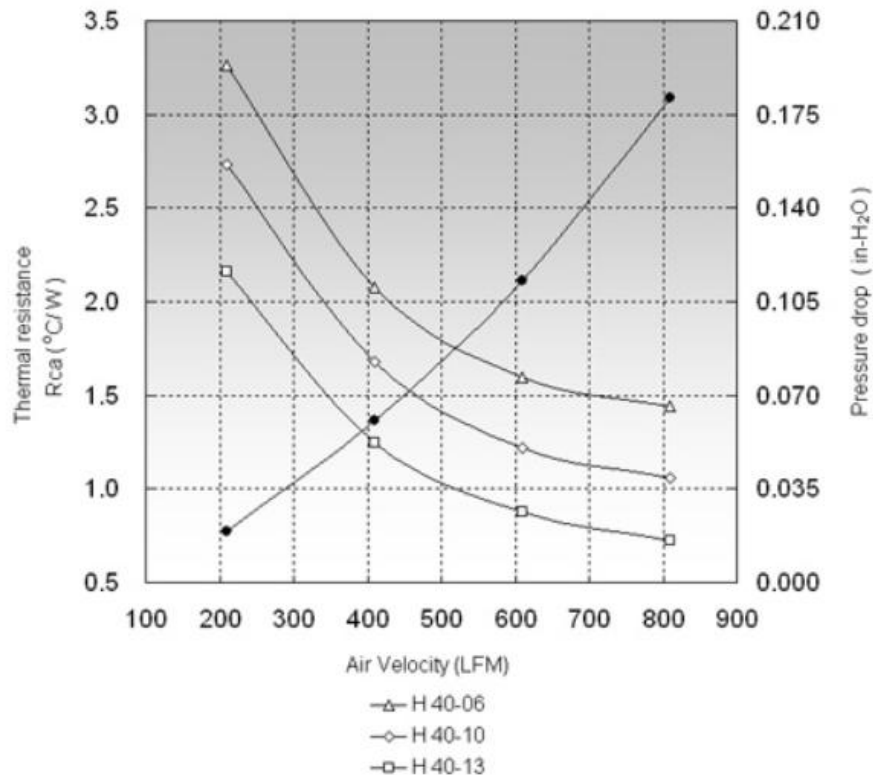

Hybrid Forge Heat Sinks

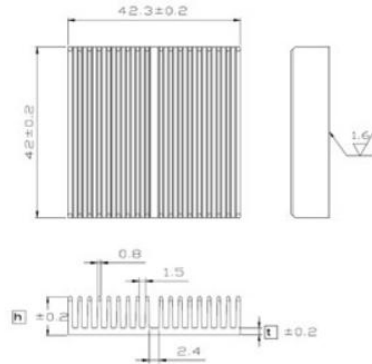

Material : Aluminum 6063

Finish : Black anodize

| Model No. | Height (mm) | Thickness (mm) |
|-----------|-------------|----------------|
| H 42.5-06 | 6.3 | 1.7 |
| H 42.5-10 | 9.5 | 1.7 |
| H 42.5-13 | 12.7 | 1.7 |

SPECIFICATION

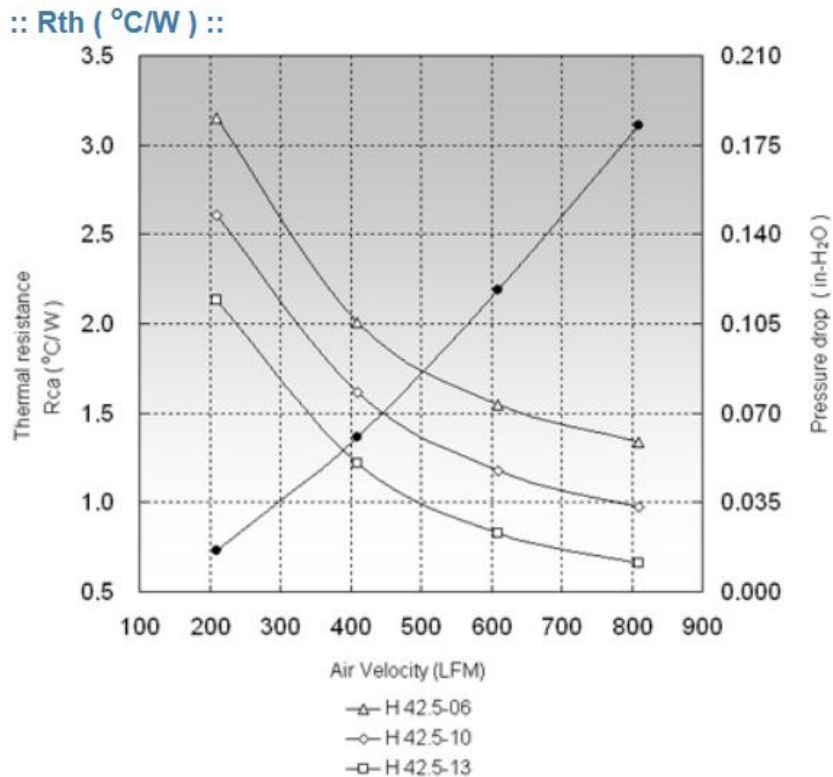

Hybrid Forge Heat Sinks

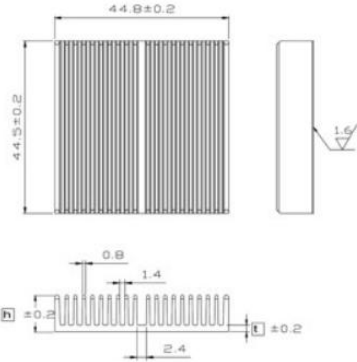

Material : Aluminum 6063

Finish : Black anodize

| Model No. | Height (mm) | Thickness (mm) |
|-----------|-------------|----------------|
| H 45-06 | 6.3 | 1.7 |
| H 45-10 | 9.5 | 1.7 |
| H 45-13 | 12.7 | 1.7 |

SPECIFICATION

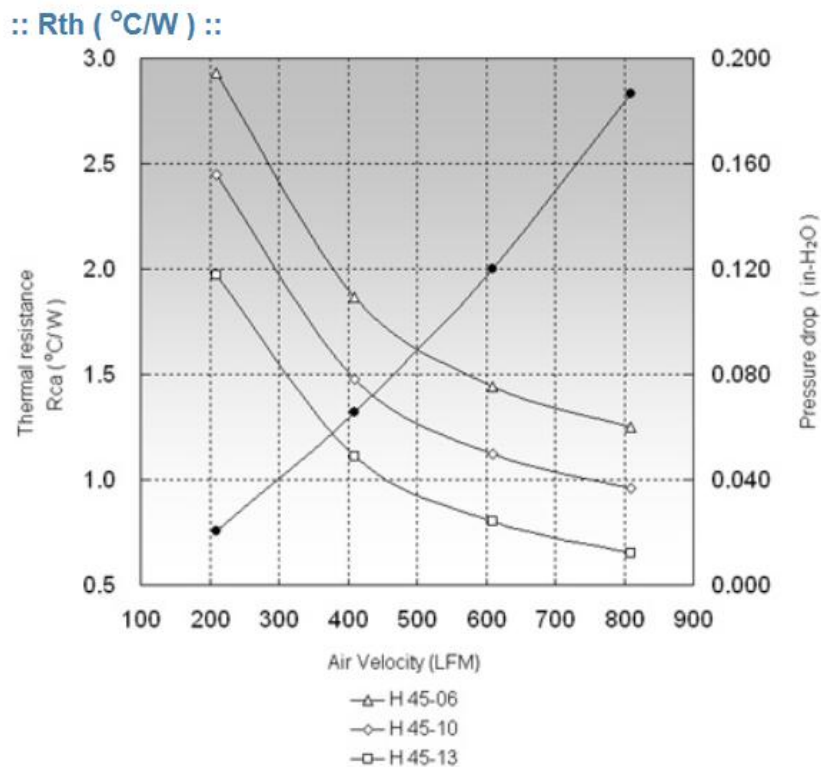

Hybrid Forge Heat Sinks

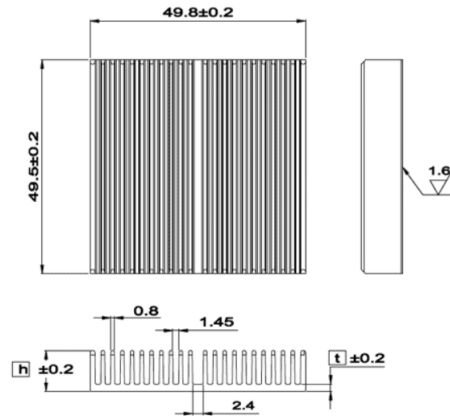

Material : Aluminum 6063

Finish : Black anodize

| Model No. | Height (mm) | Thickness (mm) |
|-----------|-------------|----------------|
| H 50-06 | 6.3 | 1.7 |
| H 50-10 | 9.5 | 1.7 |
| H 50-13 | 12.7 | 1.7 |

SPECIFICATION

:: Rth (°C/W) ::

